

PC1616/PC1832/PC1864 STANDARD INSTALLATION GUIDE

This Installation Guide provides the basic installation, wiring and programming information required to program the PowerSeries PC1616, PC1832 and PC1864 control panels. This guide shall be used in conjunction with the *PowerSeries PC1616/1832/1864 Reference Manual* which can be obtained from your local dealer or downloaded from the DSC web site at www.dsc.com.

NOTE: All necessary information required to meet UL Listing requirements is contained in this document.

Read the complete guide, then work through each step as indicated.

FEATURES		PC1616	PC1832	PC1864
OUT OF THE BOX Qty 1 <input type="checkbox"/> Cabinet Qty 1 <input type="checkbox"/> PC Module Qty 1 <input type="checkbox"/> Installation guide Qty 1 <input type="checkbox"/> User manual Qty 2 <input type="checkbox"/> Cabinet Label Qty 1 <input type="checkbox"/> Cabinet Door Plug Qty 4 <input type="checkbox"/> Standoffs Qty 16 <input type="checkbox"/> 5.6K Ω Resistors Qty 1 <input type="checkbox"/> 2.2K Ω Resistors Qty 1 <input type="checkbox"/> 1.0K Ω Resistors Qty 1 <input type="checkbox"/> 10 Ω Resistors Qty 1 <input type="checkbox"/> Grounding Kit	On-board Zones	6	8	8
	Hardwired Zones	16 (1xPC5108)	32(3xPC5108)	64 (7xPC5108)
	Wireless Zones	16	32	32
	Keypad Zone Support	✓	✓	✓
	On-board PGM Outputs	PGM 1 - 50mA PGM 2 - 300mA	PGM 1 - 50mA PGM 2 - 300mA	PGM 1, 3, 4 - 50mA PGM 2 - 300mA
	PGM Expansion	8x50mA (PC5208) 4x500 mA (PC5204)	8x50mA (PC5208) 4x500 mA (PC5204)	8x50mA (PC5208) 4x500 mA (PC5204)
	Keypads	8	8	8
	Partitions	2	4	8
	User Codes	32 + Master Codes	32 + Master Codes	32 + Master Codes
	Event Buffer	500 Events	500 Events	500 Events
SPECIFICATIONS Temp Range 0°C-49°C (32°F-120°F) Humidity (Max)..... 93%R.H. Power Supply..... 16.5VAC/40VA @60Hz Current Draw (Panel)..... 110mA (nom.) Aux+ Output..... 11.1-12.6VDC/700mA Bell Output..... 11.1-12.6VDC/700mA	Transformer Required	16.5VAC/40VA	16.5VAC/40VA	16.5VAC/40VA
	Battery Required	4Ah / 7Ah/14Ah	4Ah / 7Ah/14Ah	4Ah / 7Ah/14Ah
	Bell Output	12V/700 mA (cont)	12V/700 mA (cont)	12V/700 mA (cont)

COMPATIBLE DEVICES

Keypads (Backward compatible with all PowerSeries keypads)	Modules
PK5500 Keypad..... 125mA (max.)	T-Link TL-250/TL300 275/350mA
PK5501 Keypad..... 125mA (max.)	PC5100 2-wire Interface 40mA plus devices to 170mA max.
PK5508 LED Keypad..... 125mA (max.)	PC5132-433 Wireless Receiver 125mA
PK5516 LED Keypad..... 125mA (max.)	RF5108-433 Wireless Receiver 125mA
PC5532Z LED Keypad..... 125mA (max.)	PC5108 Zone Expander 30mA
LCD5511 Fixed Message LCD Keypad..... 85mA (max.)	PC5204 Power Supply with 4 Programmable Outputs 30mA
LED5511Z 8-zone LED Keypad 100mA (max.)	PC5208 Low Current Programmable Output Module 50mA
	PC5400 Printer/DVAC Module 65mA
	PC5401 Bi-Directional RS232 Module (Not UL Listed) 65mA
	Escort5580 Telephone Interface Module 130mA
Cabinets PC5003C 222x298x78mm (11.3x11.7x3.0in) PC500C 213x235x78mm (8.4x9.25x3.0in) Refer to the Reference Manual for alternate control cabinets	Refer to the Reference Manual for additional devices.

Classified in Accordance with ANSI/SIA CP-01-2000 (SIA-FAR)

DSC
PowerSeries™
 SECURITY SYSTEM

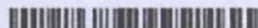

29007109R003

Hardware Installation

Begin the installation by mounting the cabinet in a dry protected area with access to unswitched AC power. Install Hardware in the sequence indicated below. Do NOT apply power until installation is complete.

NOTE: All wiring entry points are designated by arrows. All circuits are classified UL power limited except for the battery leads. Minimum 1/4" (6.4mm) separation must be maintained at all points between power limited and non-power limited wiring and connections.

1. Keybus Wiring

The 4-wire KEYBUS (red, black, yellow and green) is the communication connection between the control panel and all modules. The 4 KEYBUS terminals of all modules must be connected to the 4 KEYBUS terminals of the main control panel.

The following rules must be followed when wiring the Keybus:

- Minimum 22 AWG wire, maximum 18 AWG (2-wire twisted preferred)
- Do NOT use shielded wire
- Modules can be home run, connected in series or can be T-tapped provided that the maximum wire distance from the control panel to any module does not exceed 1,000 feet (305m)
- No more than 3,000 feet (915m) of wire can be used in total

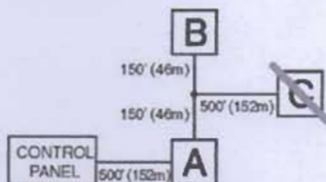

2. Zone Wiring

Zones can be wired for Normally Open, Normally Closed Contacts with Single-end-of-line (SEOL) resistors or Double End-of-Line (DEOL) resistors. Observe the following guidelines

- For UL Listed Installations use SEOL or DEOL only.
- Minimum 22 AWG wire, maximum 18 AWG
- Do NOT use shielded wire
- Wire run resistance shall not exceed 100Ω. Refer to the chart below.

Burglary Zone Wiring Chart

Wire Gauge	Maximum wire length to End of Line Resistor (feet/meters)
24	1900 / 579
22	3000 / 914
20	4900 / 1493
19	6200 / 1889
18	7800 / 2377

Figures are based on maximum wiring resistance of 100 ohms.

- Section [001-004] Selects Zone Definition
- Section [013] Opt [1] Selects Normally Closed or EOL resistors
- Section [013] Opt [2] Selects Single EOL or Double EOL resistors.

Zone Status

Loop Resistance

- 0Ω (shorted wire/loop)
- 5600Ω (contact closed)
- infinite (broken wire, open)
- 11,200Ω (contact open)

Loop Status

- Fault
- Secure
- Tamper
- Violated

Normally Closed Loops - Do NOT use for UL Installations

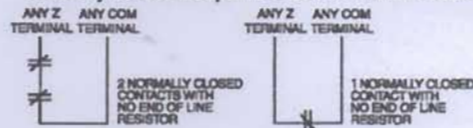

Single End-of-Line Resistor Wiring

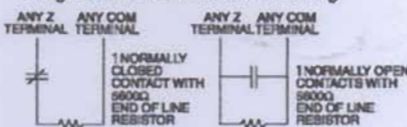

Double End-of-Line Resistor Wiring



3. Bell Wiring

These terminals supply 700mA of current at 12Vdc for commercial installations and 11.1-12.6 Vdc for residential installations (e.g. DSC SD-15 WULF). To comply with NFPA 72 Temporal Three Pattern requirements:

Program Section [013] Opt [8] ON.

The Bell output is supervised and power limited. If unused, connect a 1000Ω resistor across Bell+ and Bell- to prevent the panel from displaying a trouble. See [*][2].



NOTE: Bell output is current limited by 2A PTC

NOTE: Steady, Pulsed and Temporal Three Pattern alarms are supported.

Hardware Installation (Cont.)

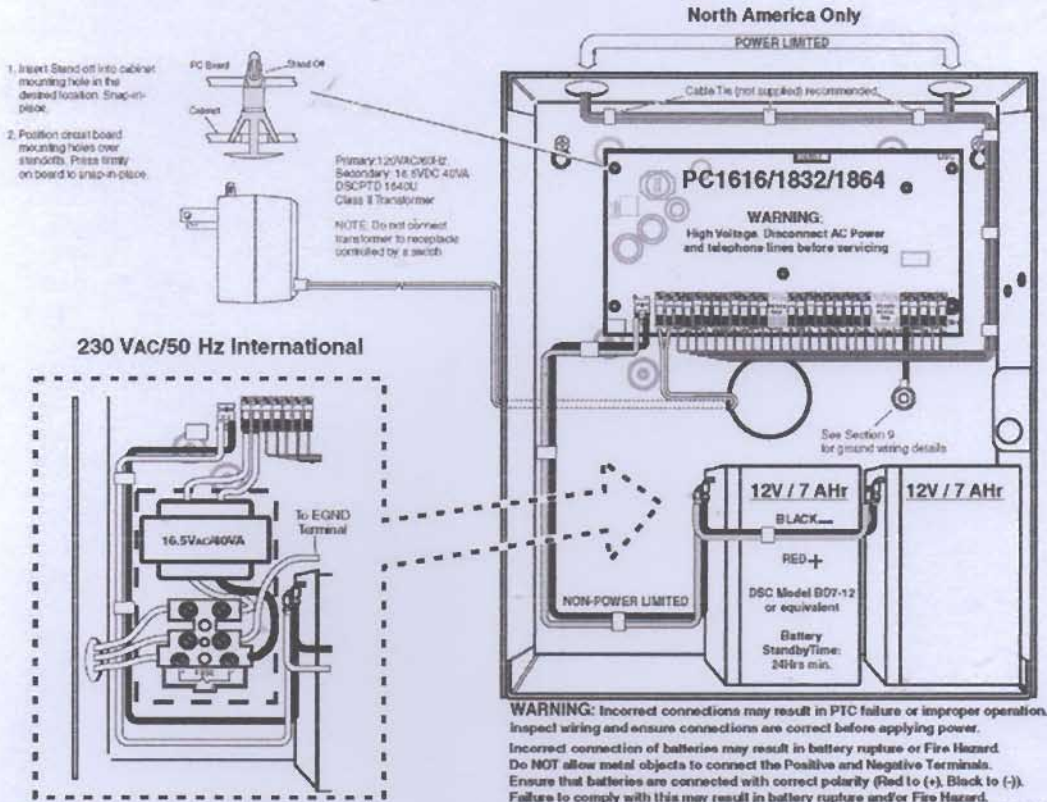

1. Insert Stand off into cabinet mounting hole in the desired location. Snap-in-place.
2. Position circuit board mounting holes over standoffs. Press firmly on board to snap-in-place.

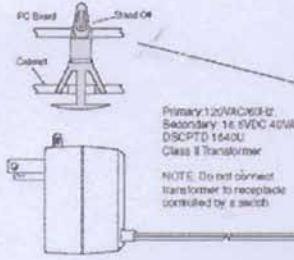

230 VAC/50 Hz International

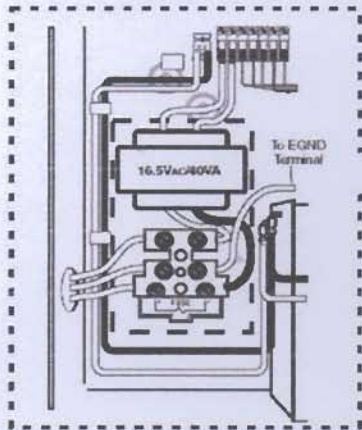

IMPORTANT:

- a) This equipment, Alarm Controller PC1616/1832/1864 shall be installed and used within an environment that provides the pollution degree max 2 and overvoltages category II NON-HAZARDOUS LOCATIONS, indoor only. The equipment is FIXED and PERMANENTLY connected and is designed to be installed by service persons only. [service person is defined as a person having the appropriate technical training and experience necessary to be aware of hazards to which that person may be exposed in performing a task and of measures to minimize the risks to that person or other persons.]
- b) The connection to the main supply must be made as per the local authorities rules and regulations. An appropriate disconnect device must be provided as part of the building installation. Where it is not possible to rely on identification of the neutral in the AC Mains supply the disconnecting device must disconnect both poles simultaneously (line and neutral). The device shall disconnect the supply during servicing.
- c) The equipment enclosure must be secured to the building structure before operation.
- e) Internal wiring must be routed in a manner that prevents:
 - Excessive strain on wire and on terminal connections,
 - Loosening of terminal connections,
 - Damage of conductor insulation.
- f) Disposal of the used batteries shall be made according to the waste recovery and recycling regulations applicable to the intended market.
- g) Before servicing, DISCONNECT the telephone connection.

WARNING:
High Voltage. Disconnect AC Power
and telephone lines before servicing

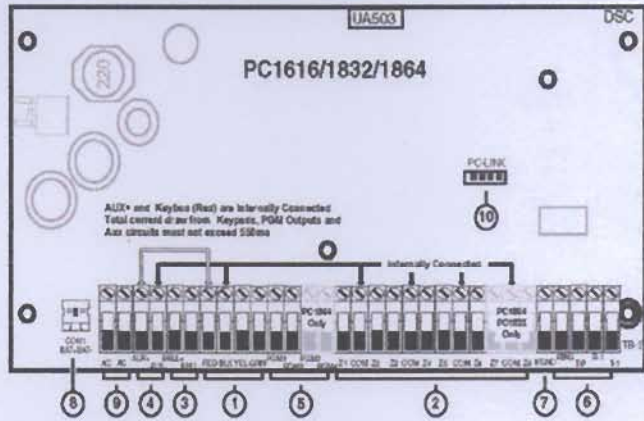

See corresponding Section Number/Text for wiring details.

Hardware Installation (Cont.)

4. AUX Power Wiring

The control panel can provide a maximum of 700mA of current for modules, powered detectors, relays, LED's etc.... If the total current required exceeds 700mA an additional power supply is required (e.g., PC5200, PC5204). See list below.

NOTE: Min/max operating voltages for devices, sensors and modules is 9.5Vdc - 14Vdc

Refer to the list of **Compatible Devices** on the first page for the current draw of individual devices

5. PGM Wiring

PGMs switch to ground when activated by control panel. Connect the positive side of the device to be activated to the AUX+ Terminal. Connect the negative terminal to the PGM.

current output is as follows

- PGM 1, 3, 4 50mA
- PGM 2 300mA

For currents levels greater than 300mA a relay is required.

PGM2 can also be used for 2-wire smoke detectors.

NOTE: Use SEOL resistors on Fire Zones ONLY.

2-wire Smoke Detectors Initiating Circuit

- Style B (Class B), Supervised, Power Limited
- Compatibility Identifier PC18-1
- DC Output Voltage 9.8-13.8 VDC
- Detector Load 2 mA (MAX)
- Single-end-of-line (SEOL) Resistor 2200Ω
- Loop Resistance 24Ω (MAX)
- Standby Impedance 1020Ω (NOM)
- Alarm Impedance 570Ω (MAX)
- Alarm Current 89 mA (MAX)

Compatibility ID For FSA-210B Series is: FS200

Compatible 2-wire
Smoke Detector
DSC FSA-210B Series



NOTE:
Refer to Installation Manual and
Smoke Detector Instruction Sheet
when positioning detectors.

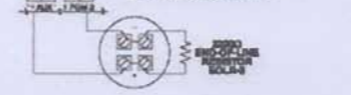

**NOTE: Do NOT combine modules from different Manufacturers
On the same circuit. Operation may be impaired.**

PGM 1, LED Output with current limiting resistor and Optional Relay driver output

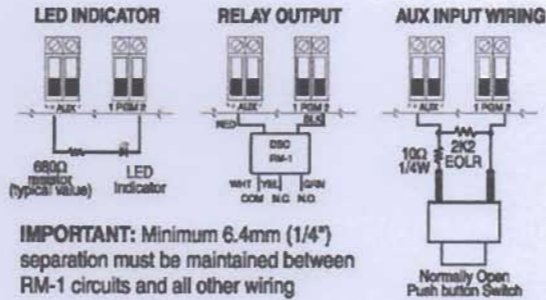

**IMPORTANT: Minimum 6.4mm (1/4")
separation must be maintained between
RM-1 circuits and all other wiring**

4-wire Smoke Detectors



Smoke Detector must be ending type (e.g., DSC FSA 410B Series)
To reset smoke detector, Enter [9] [7] [7]

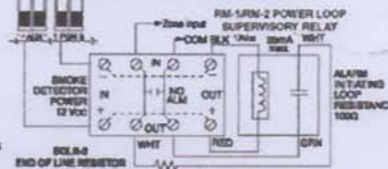

Compatible 4-wire
Smoke Detector
DSC FSA-410B Series

- FSA-410B
- FSA-410BT
- FSA-410BS
- FSA-410BST
- FSA-410BLST
- FSA-410BR
- FSA-410BRT
- FSA-410BRS
- FSA-410BRST
- FSA-410BLRST

6. Telephone Line Wiring

Wire the telephone connection terminals (TIP, Ring, T-1, R-1) to an RJ-31X Connector as indicated.

For connection of multiple devices to the telephone line, wire in the sequence indicated.

Telephone format is programmed in section [350].

Telephone Call Directions are programmed in section [351]-[376].

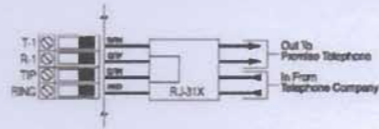

7. Ground

Ground Installation

Tighten nut to break point and make good connection to the cabinet

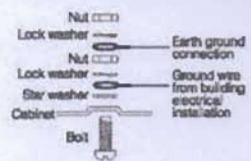

8. Battery

A sealed, rechargeable, lead acid battery or gel type battery is required to meet UL requirements for power standby times.

NOTE: UL Residential/Commercial Burglary installations require 4Hrs Power Standby time.

NOTE: UL/ULC Residential Fire & Home Care installations require 24 Hr power standby.

NOTE: ULC Commercial Burglary and Fire monitoring installations require 24 Hr power standby.

Standby Battery Guide

Battery Charging Current: 400 mA

Batt Size	Standby	
	4Hr	24Hr
4Ahr	700mA	---
7Ahr	700mA	190mA
14Ahr	700mA	470mA

NOTE:

Replace batteries every 3-5 years. Battery capacity will deteriorate with age and number of charge/discharge cycles

9. AC Wiring

AC Wiring

UL Listed Installations

Primary: 120VAC/60Hz/0.33A

Secondary: 16.5VAC/40VA

DSCPTD 1640 Plug-in, Class 2 Transformer.

NOTE: Do not connect transformer to a receptacle controlled by a switch. (UL Listed Installations Only)

TESTING & TROUBLESHOOTING

Testing:

- Power up system
- Program options as required (See *Programming Section* on reverse side)

Note: For advanced programming refer to the PC1616/1832/1864 Reference manual

- Violate, then restore zones
- Verify correct *Reporting Codes* are sent to the Central Station

Troubleshooting:

LCD5500 LCD Programmable-Message Keypad

- Press [*][2] to view a trouble condition.
- The trouble light will flash and the LCD will display the first trouble condition present.
- Use the arrow keys to scroll through all trouble conditions present.

NOTE: When additional information is available for a specific trouble condition a [*] will appear on the display. Press the [*] key to view the additional information

LED Keypads, LCD Fixed Message Keypads

- Press [*][2] to view a trouble condition.
- The trouble light will flash.
- Refer to the *Trouble Summary* chart below to determine the trouble condition(s) present.

Trouble Summary:

Light [1]* Service Required - Press [1] for more information

- [1] Low Battery
- [2] Bell Circuit
- [3] General System Trouble
- [4] General system Tamper
- [5] Module Supervision
- [6] RF Jam Detected
- [7] PC5204 Low Battery
- [8] PC5204 AC Failure

Light [2] AC Trouble

Light [3] Telephone Line Trouble

Light [4] Failure to Communicate

Light [5]* Zone Fault -Press [5] for more information

Light [6]* Zone Tamper - Press [6] for more information

Light [7]* Wireless Device Low Battery - Press [7] for more information

Light [8] Loss of Time or Date